

LOC	DIST	REVISIONS			
TR	LYR	DESCRIPTION	DATE	DWN	APPR
AJ	16	AZ	REVISED PER EC 0514-0288-02	18DEC02	DD KW

- ① BRASS PER QQ-B-626.
- ② BERYLLIUM COPPER PER ASTM-B-196
- ③ NYLON PER ASTM-D-4066, BLACK
- ④ POLYMETHYLPENTENE GENERAL PURPOSE, NATURAL
- ⑤ .000030 MINIMUM GOLD PER MIL-G-45204.
- ⑥ .000050 MINIMUM GOLD PER MIL-G-45204.
- ⑦ .000100 MINIMUM GOLD PER MIL-G-45204.
- ⑧ RG-174/U, RG-179A/U, RG-187/U, AND 21-598.
- ⑨ SHIELDED CABLE #26=NAS-702 CLASS A & C, AND MIL-W-16878 TYPES E & EE, SHIELDED CABLE #24=NAS-702 CLASS A & C, AND MIL-W-16878 TYPES E & EE, SHIELDED CABLE #22=NAS-702 CLASS C, AND MIL-W-16878 TYPE E, AND MIL-C-7078A TYPE I NUMBER 1 DIELECTRIC .068 O.D.
- 10. SEE IS 408-1770
- ⑫ NYLON PER ASTM-D-4066, NATURAL
- ⑬ DIELECTRIC MATERIAL: VALOX 325 WHITE

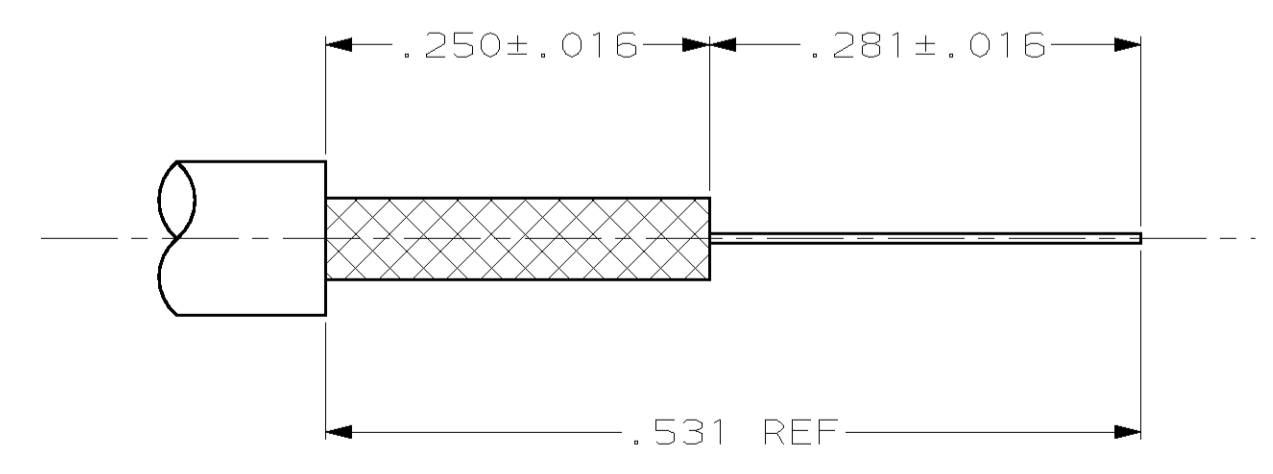
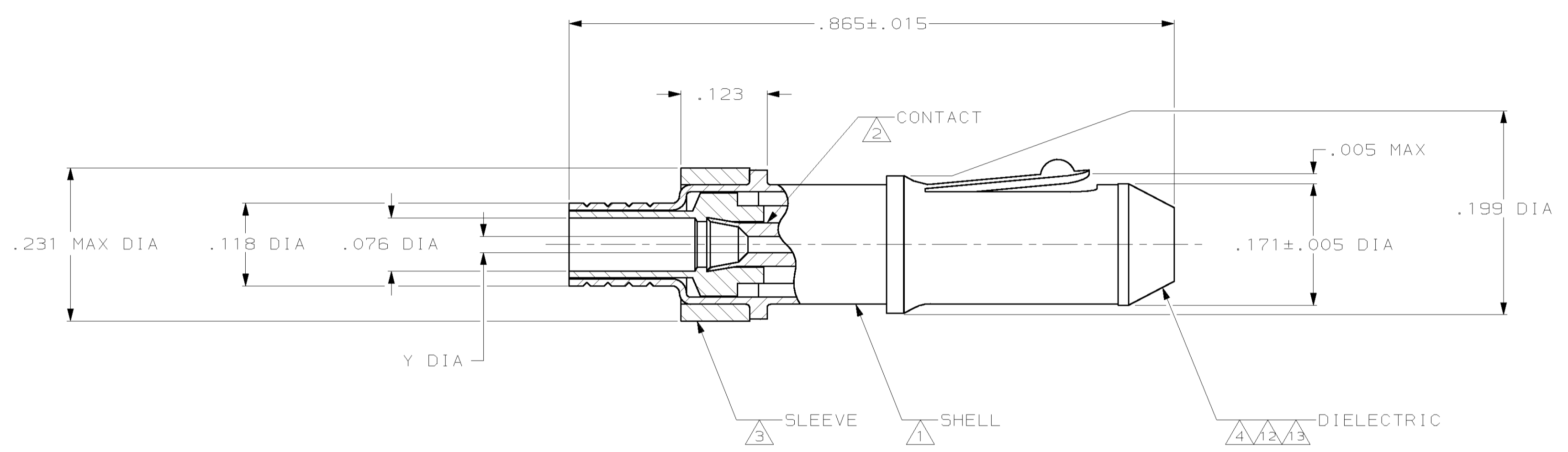

VIEW D  
RECOMMENDED STRIP LENGTH

⑬	⑤	⑤	.030 OUNCES	-	-	.032 ± .003	-	-	-	2-201143-5
⑬	⑤	⑤	.030 OUNCES	-	-	.032 ± .003	-	-	-	2-201143-4
	⑦	⑦	.030 OUNCES	-	-	.032 ± .003	-	-	-	201143-7
	⑤	⑤	.030 OUNCES	-	-	.032 ± .003	-	-	-	201143-5
	⑤	⑤	.030 OUNCES	-	-	.042 ± .003	-	-	-	201143-3
	⑤	⑤	.030 OUNCES	-	-	.023 ± .003	-	-	-	201143-1

CONTACT PLATING	SHELL PLATING	WEIGHT	CABLE OR WIRE SIZE	CRIMP TOOL	Y	③ FERRULE QTY=1	② SPRING RETENTION QTY=1	① PIN ASSY QTY=1	PART NUMBER
-----------------	---------------	--------	--------------------	------------	---	-----------------	--------------------------	------------------	-------------

THIS DRAWING IS A CONTROLLED DOCUMENT.

DWN: J. LIPPERT 08 JAN 90  
 CHK: M. SINFED 23 FEB 90  
 APVD: EL ADAMS 23 FEB 90

AMP TYCO Electronics  
 Harrisburg, PA 17105-3608

PRODUCT SPEC: 108-12021  
 APPLICATION SPEC: -

SIZE: - CAGE CODE: - DRAWING NO: A100779C-201143  
 WEIGHT: SEE TABLE  
 CUSTOMER DRAWING

RESTRICTED TO: -  
 SCALE: 8:1 SHEET 1 OF 1 REV AZ